

KELVIN LED CLAMP

Mounting	: Clamp
Lamps description	: 30 TOP LED 2700k 275 lm total - cri 95 - 8w
Environment	: Indoor
Finish	: Anthracite, White, Black
Technical description	: Adjustable table lamp providing direct lighting, with pantograph arm and adjustable head. Fused aluminum alloy body. Die-cast aluminum outer head, with injection-molded methacrylate diffuser. Painted CNC machined extruded aluminum CLAMP. Extruded aluminum alloy square tube (12x12mm) structure, machined mechanically, so that it houses a stainless steel load-compensation spring and injection-molded acetal resin sliding blocks. 3 mm diameter wire outer tie rods. The ON/OFF switch is electronic with optical mechanism located in the head.

ELECTRICAL

Emergency	: Without
Voltage (V)	: 100/240V 50/60 Hz

PHYSICAL

Supply	: Power cord
Cord length(mm)	: 1800
Construction material	: Aluminum
Weight (kg)	: 1,63

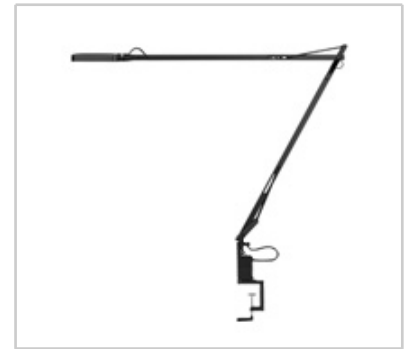

Kelvin LED Clamp

design by Antonio Citterio with Toan Nguyen

Adjustable table lamp providing direct lighting

Reference Code

- F3324030A Shiny black
- F3324009A Shiny white
- F3324033A Anthracite

Certifications

